

Sanifos 1300

Grey water, black water

The Sanifos 1300 is a station designed to lift waste water from buildings, business premises or homes. It consists of a 1300 litre tank and two pumps. It is available in 3 different configurations: single-phase grinder impeller, single-phase vortex impeller or three-phase vortex impeller. This station is delivered with an interactive monitoring system: the Smart control box.



PERFORMANCE

- Total head: 17 m
- Max. flow rate: 32 m³/h

DEPENDING ON MODEL

PRODUCT BENEFITS

- Easy installation: pre-mounted hydraulics
- Guide bar for easy maintenance
- Variable incoming water connection
- Self-cleaning sloping tank bottom
- Delivered with Smart control box



DELIVERED AS STANDARD



- Tank with pre-assembled hydraulics, 2 isolation valves, 2 non-return valves and 3 floats installed in the tank. 2 submersible pumps (either grinder or vortex), stainless steel handling chains with fixing shackles, cable glands, waterproof terminal blocks, 1 tank seal, 1 drilling template, Smart control unit with alarm



Smart box (with 2 pump versions)



Pro X K2 grinder



Vortex



Sanipump VX S



Sanipump GR S

OPTIONAL EXTRAS (SEE ACCESSORIES PAGES)

Sanifos 610/1300 extension

Barcode: 3308815077826

Product code: 40503



DIMENSIONS

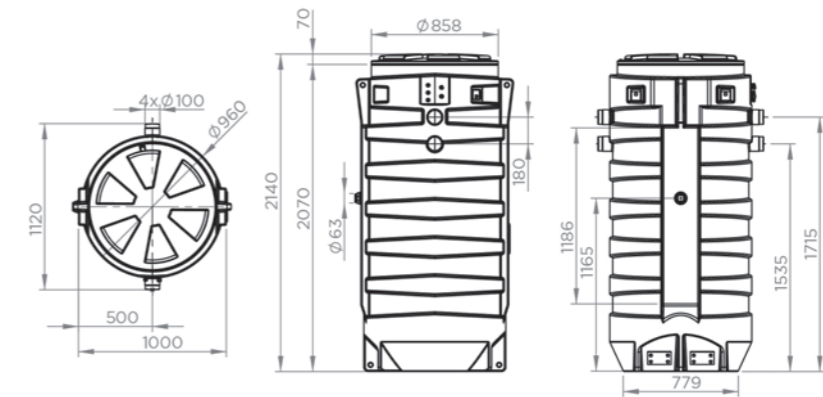

Dimensions (mm)

CURVE

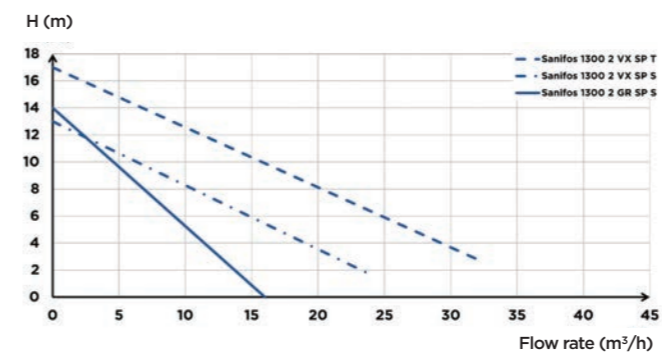

CONNECTIONS



- External inlet diameter : 160 mm
- External discharge diameter : 63 mm
- External ventilation diameter : 100 mm

	Sanifos 1300 2GR SP S	Sanifos 1300 2VX SP S	Sanifos 1300 2VX SP T
Type of control box	Smart	Smart	Smart
Number of pumps	2	2	2
Material			
Tank	PE	PE	PE
Pipework	PVC	PVC	PVC
Electrical features			
See electrical features for pump on page 88			
Hydraulics			
Max head (m)	14	13	17
Max. flow rate (m ³ /h)	16	25	32
External inlet diameter (mm)	160	160	160
External discharge diameter (mm)	63	63	63
External ventilation diameter (mm)	100	100	100
Total volume (L)	1300	1300	1300
Useable volume (L)	350	350	350
Alarm level (mm)	930	930	930
Min. incoming water connection (mm)	600	600	600
Max. incoming water connection (mm)	1600	1600	1600
Max. incoming water connection if option is available (mm)	2000	2000	2000
Type of impeller	Pro X K2 grinder	vortex	vortex
Type of activation	float	float	float
Identification and logistics			
Gross weight (kg)	138	138	138
Barcode	3308815077796	3308815077802	3308815077819
Product code	40008	40009	40010