

SANICUBIC®

SANICUBIC® 1
SANICUBIC® 1 WP
SANICUBIC® 2 Classic
SANICUBIC® 2 Pro
SANICUBIC® 2 XL

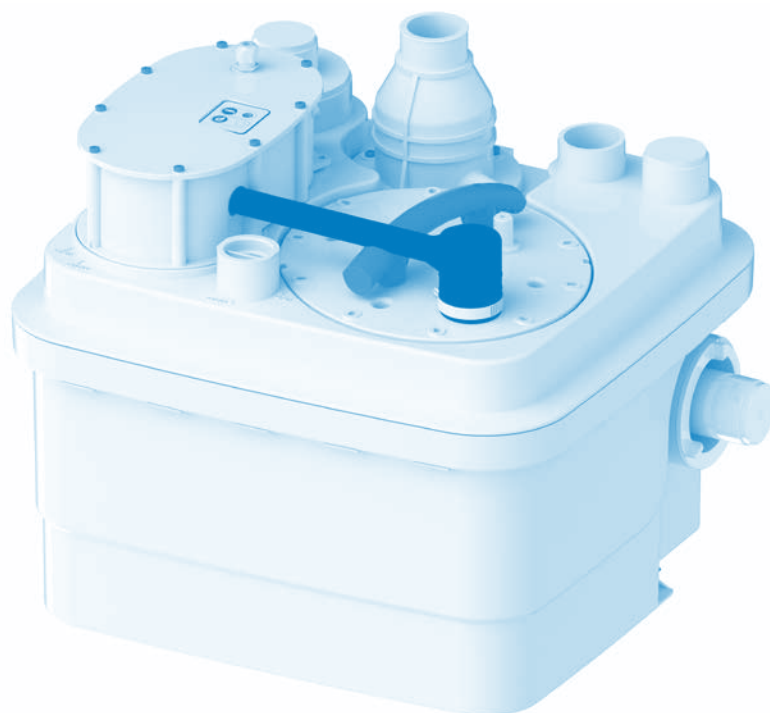

**Notice de service / montage • Operating / installation manual •
Bedienungs- / Installationsanleitung • Manuale per l'uso e
l'installazione • Gebruikers- / installatiehandleiding •
Руководство по эксплуатации и установке • 操作/安装指南**

CONTENTS

Glossary	19
1. Safety	20
1.1 Identification of warnings.....	20
1.2 General points.....	20
1.3 Intended use.....	20
1.4 Qualification and training of staff	20
1.5 Safety instructions for maintenance, inspection and installation.....	20
1.6 Risks and consequences of non-compliance with the operating manual.....	20
2. Transport / Temporary storage / Returns / Disposal	20
2.1 Receiving inspection.....	20
2.2 Transport.....	20
2.3 Temporary storage / Packaging	20
2.4 Returns.....	20
2.5 Disposal	20
3. Description.....	21
3.1 General description.....	21
3.2 Scope of supply	21
3.3 Rating plate.....	21
3.4 Design and operating mode.....	21
3.5 Technical data	22
3.6 Control box	23
3.6.1 Electrical characteristics.....	23
3.6.2 Technical characteristics of the detection device	23
3.6.3 Dimensions of the remote control box	23
3.7 Alarm unit.....	23
3.7.1 Technical characteristics of the alarm device	23
3.7.2 Dimensions of the remote alarm unit.....	23
3.7.3 Option of connection to an external alarm.....	23
3.8 Sump tank.....	23
3.9 Pumped fluids	23
3.10 Noise level	23
4. Installation / Fitting	24
4.1 Installing the pumping station	24
4.2 Electrical connection	24
4.3 Fitting the pumping station.....	24
4.4 Pipe connections.....	24
4.4.1 Inlet pipes.....	24
4.4.2 Discharge piping	24
4.4.3 Ventilation pipe.....	24
4.5 Cellar drying.....	25

5. Commissioning / Decommissioning	25
5.1 Commissioning.....	25
5.1.1 Prerequisites for commissioning	25
5.2 Application limit.....	25
5.3 Starting frequency.....	25
5.4 Commissioning with the control box.....	25
5.5 Decommissioning.....	25
6. Operation	25
6.1 Operation of the SANICUBIC® Control box.....	25
6.1.1 Operation of the SANICUBIC® 1 control keypad (IP67).....	26
6.1.2 Operation of the SANICUBIC® 2 Classic /SANICUBIC® 2 Pro / SANICUBIC® 2 XL remote control box	26
6.2 SANICUBIC® alarm unit	26
6.2.1 Operation of the SANICUBIC® 1/ SANICUBIC® 1 WP / SANICUBIC® 2 Classic / SANICUBIC® 2 XL wired alarm unit	26
6.2.2 Operation of the SANICUBIC® 2 PRO HF alarm unit	26
6.3 Messages and faults.....	27
7. Maintenance	27
7.1 General information / Safety instructions.....	27
7.2 Maintenance and inspection operations	27
7.3 Maintenance contract.....	27
7.4 Emergency service with a single pump	27
7.5 Checking the hydraulics of each motor.....	27
7.5.1 General information	27
7.5.2 Disassembly of the hydraulics	27
7.5.3 Disassembly and inspection of the compression chambers and level sensors.....	28
7.5.4 Reassembly of the level sensors.....	28
7.5.5 Reassembly.....	28
7.5.6 Tightening torque.....	28
7.6 Checklist for commissioning / inspection (1) and maintenance (2)	28
8. Incidents: causes and solutions.....	28
APPENDICES.....	29

Copyright / Legal notices

SANICUBIC® Operating / installation manual
Original operating instructions

All rights reserved. The contents of this document must not be reproduced, modified or disclosed to third parties except upon written consent from the manufacturer.

This document may be subject to change without notice.

SFA – 41 Bis Avenue Bosquet – 75007 PARIS 03.2017

GLOSSARY

Ventilation pipe

Ventilation duct limiting pressure variations inside the blackwater pumping station. The pumping station must be ventilated above the roof.

ND (Nominal Diameter)

Parameter used to characterise parts that are suitable for each other, for example: pipes, connections, sleeves.

Wastewater

Spent or used water that is not clean because it has been discharged from homes, commercial establishments, farms, and industries.

EN 12050-1

Current European standard for pumping stations for effluents containing faecal material intended for discharge below the back-flow level in buildings and on land.

Noise level

Expected sound emissions, expressed in sound pressure level LpA in dB(A).

Back-flow level

The highest level that can reach the wastewater flowing back into a discharge system.

Separator

Equipment which prevents, by gravity, the penetration of harmful substances into the discharge system by separating them from wastewater, for example: grease trap.

Pumping station for blackwater

Facilities for the automatic collection and pumping of wastewater and blackwater above the back-flow level.

Dual station

Pumping station for blackwater equipped with a second pump of the same power that starts automatically when needed.

Inlet piping

Line through which wastewater from sanitary fixtures is routed to the pumping station.

Discharge piping

Piping for raising wastewater above the back-flow level routing it to the sewer.

Useful

Volume to be discharged between the start level and the stop level.

Clearance





The clearance is the space that needs to be provided to allow comfortable fitting and installation of the product.

1 SAFETY

ATTENTION

This device may be used by children who are at least 8 years old, by people with reduced physical, sensory or mental capacities or those without knowledge or experience, if they are properly supervised and if the instructions relating to using the device completely safely have been given to them and the associated risks have been understood. Children must not play with the device. Cleaning and maintenance undertaken by the user must not be carried out by unsupervised children.

1.1 Identification of warnings

Symbol	Meaning
 DANGER	DANGER This term defines a high risk of danger, which can lead to death or serious injury, if not avoided.
 WARNING	WARNING This term defines a hazard which could cause a risk to the machine and its operation, if it is not taken into account
	Dangerous area This symbol, in combination with a keyword, characterises hazards that could lead to death or injury.
	Dangerous voltage This symbol, in combination with a keyword, characterises dangers associated with the voltage and provides information on voltage protection.
 WARNING	Property damage This symbol, in combination with the keyword WARNING , characterises dangers to the machine and its proper operation.

1.2 General points

This operating and installation manual contains important instructions to follow for the fitting, operation and maintenance of the SANICUBIC® pumping station. Following these instructions guarantees safe operation and prevents injury and property damage.

Please follow the safety instructions in every section.

Before fitting and commissioning the pumping station, the qualified installer/user concerned must read and understand all these instructions.

1.3 Intended use

Only use the pumping station in the fields of application described in this documentation.

- The pumping station must only be operated in technically perfect conditions.
- Do not use a partially assembled pumping station.
- The pumping station must only pump the fluids described in this documentation.
- The pumping station must never operate without pumped fluid.
- Contact us for operating modes not described in this documentation.
- Never exceed the usage limits defined in the documentation.
- The safe use of the pumping station is only guaranteed if used as intended (=> section 5.2, page 7).

1.4 Qualification and training of staff

Commissioning and maintenance of this device must be performed by a qualified professional. Please refer to installation standard EN 12056-4.

1.5 Safety instructions for maintenance, inspection and installation

- Any alteration or modification of the pumping station will void the warranty.
- Only use original parts or parts recognised by the manufacturer. The use of other parts may void the manufacturer's liability for any resulting damage.
- The operator must ensure that all maintenance, inspection and installation work is carried out by qualified, authorised staff having previously studied this operating and installation manual.
- Before working on the pumping station, switch it off and unplug the pumping station's power plug.
- You must follow the procedure for shutting down the pumping station described in this operating manual.

- Pumping stations discharging fluids that may be harmful to health must be decontaminated. Before restarting the pumping station, follow the commissioning instructions. (⇒ section 5.1, page 7)

- Keep unauthorised people (children, for example) away from the pumping station.
- Never exceed the usage limits defined in the documentation.
- Follow all the safety precautions and instructions in this operating and installation manual.

This operating manual must always be available on site so it can be accessed by qualified staff and the operator.

1.6 Risks and consequences of non-compliance with the operating manual

Failure to comply with this operating and installation manual will result in the loss of warranty rights and rights to damages.

2 TRANSPORT / TEMPORARY STORAGE / RETURNS / DISPOSAL

2.1 Receiving inspection

- When receiving goods, check the condition of the pumping station's packaging.
- In case of damage, note the exact damage and immediately notify the dealer in writing.

2.2 Transport

DANGER

Dropping the pumping station

Risk of injury if the pumping station is dropped!

- ▷ Keep the pumping station horizontal when moving it.
- ▷ Observe the indicated weight.
- ▷ Never suspend the pumping station by the power cord.
- ▷ Use suitable means of transport.

- ✓ The pumping station has been inspected to make sure there is no damage due to transport.

Choose suitable means of transport according to the weight table

Table 1: Weight of the pumping station

Model	Gross Weight (including packaging and accessories) [kg]
SANICUBIC® 1	19.8
SANICUBIC® 1 WP	26.7
SANICUBIC® 2 Classic	35.5
SANICUBIC® 2 Pro	33.0
SANICUBIC® 2 XL	101.0
SANICUBIC® 2 XL Three-phase	102.0

2.3 Temporary storage / Packaging

In the case of commissioning after an extended storage period, take the following precautions to ensure storage of the pumping station:

WARNING



Wet, dirty or damaged openings and junction points. Leaks or damage to the pumping station!

- ▷ Clear the pumping station's blocked openings at the time of installation.

2.4 Returns

- Properly drain the pumping station.
- Rinse and decontaminate the pumping station, especially if it has transported harmful, explosive, hot or otherwise dangerous liquids.

2.5 Disposal



The device must not be disposed of as household waste and must be disposed of at a recycling point for electrical equipment. The device's materials and components are reusable. The disposal of electrical and electronic waste, recycling and recovery of any form of used appliances contribute to the preservation of our environment.

3 DESCRIPTION

3.1 General description

This device is a compact pumping station. SANICUBIC® 1 and SANICUBIC® 1 WP are pumping stations specially developed for individual use (detached house or small commercial premises). SANICUBIC® 2 Classic and SANICUBIC® 2 Pro are pumping stations specially developed for individual, commercial and small community use (small buildings, shops, public places). SANICUBIC® 2 XL is a pumping station specially designed for community use (professional buildings, restaurants, industries, schools, hotels or shopping centres). These devices comply with the EN 12050-1 standard (pumping station for waste water containing faeces) as well as the European directives on construction products, electrical safety and electromagnetic compatibility. DoP available on our website in the product file («Diagrams and technical data sheet» tab).

3.2 Scope of supply

Depending on the model, the following components are provided:

- Sump tank with 1 or 2 pumps and 3 level sensors, depending on the model
- Remote control box (except SANICUBIC® 1)
- Wired or HF alarm unit, depending on the model
- Check valves
- Mounting kit (screws, pegs)
- Connecting sleeves for inlet, discharge and ventilation piping
- Clamps for the connecting sleeves
- Vent turbine

3.3 Rating plate

Examples:

Pumping station

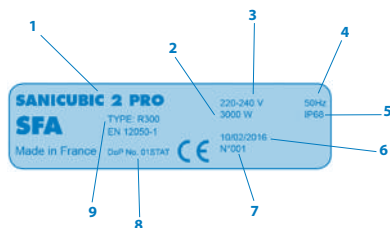

1	Name of the pumping station
2	Power consumption of the motors
3	Power supply
4	Frequency
5	Protection index
6	Date of production
7	Identification number
8	Declaration of performance reference (DoP)
9	Type of certification

Control box

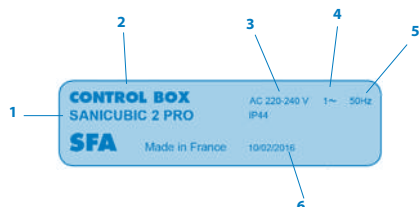

1	Name of the pumping station
2	Name of the control box
3	Power supply
4	Phase type
5	Frequency
6	Protection index
7	Date of production

3.4 Design and operating mode

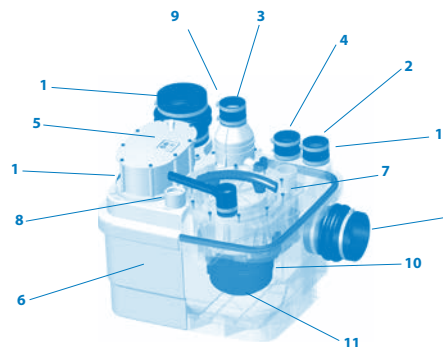

Table 2: SANICUBIC® 2 Pro illustration

1	Inlet	Ø ext.40/50/100/110 mm
2	Inlet	Ø ext. 40/50 mm
3	Waste pipe	Ø ext. 50 mm
4	Ventilation opening	Ø ext. 50 mm
5	Level sensor (dip tube)	
6	Tank	
7	Access panel	
8	Control opening	
9	Built-in check valve	
10	Engine-pump assembly	
11	Shredding system	

The pumping station is equipped with several horizontal and vertical inlet openings for 40/50/100/110 mm outside diameter piping (1) and 40/50 mm outside diameter piping (2). The engine-pump assembly (10) carries the pumped fluid in the vertical discharge piping with an outside diameter of 50 mm (3) and outside diameter of 110 mm for the SANICUBIC® 2 XL. The ventilation duct (4) allows the tank to always remain at atmospheric pressure.

Operating mode:

Effluents enter the pumping station through the horizontal and vertical inlet openings (1) (2). They accumulate in a gas-tight, smell-proof and watertight plastic tank (6). Controlled by a level sensor (5) and a control box, effluents are shredded by the shredding system (11) or carried away by a vortex impeller for the SANICUBIC® 2 XL and automatically pumped, when they reach a certain level in the tank, by one or two pumps, depending on the model, (10) above the back-flow level to flow into the discharge line.

- SANICUBIC® 1/SANICUBIC 1® WP contains one pump equipped with a high-performance shredding system.

- SANICUBIC® 2 Classic/SANICUBIC® 2 Pro contains two independent pumps. Each of these pumps is equipped with a high-performance shredding system. Both pumps operate each in turn, alternately. In case of abnormal operation, both engines run simultaneously (or if one pump fails, the other takes over).

- SANICUBIC® 2 XL contains two independent pumps, each with a clearance of 50 mm. Both pumps operate each in turn, alternately. In case of abnormal operation, both engines run simultaneously (or if one vortex pump fails, the other takes over).

Level sensor / Dip tube:

• 2 Long dip tubes

During normal operation, as soon as the effluents reach the long tube's actuation level in the tank, the pumping system switches on.

• Short dip tube

During abnormal operation, if the effluents reach the highest level in the tank (short tube), an audible and visual alarm system is activated and the pumping system switches on (if it is not faulty).

3.5 Technical data

Pumping station for blackwater (submersible for the SANICUBIC® 1 WP, SANICUBIC® 2 Classic, SANICUBIC® 2 Pro, SANICUBIC® 2 XL versions).

SANICUBIC® 1 / SANICUBIC® 1 WP

Type of current	Single-phase	
Voltage	220-240V	
Frequency	50/60 Hz	
Motor - Pump	Oil bath cooled Thermal overload protection Class F insulation	
Type of pump	Shredding by blade-plate	
Motor power consumption (for one motor)	1,500 W	
Maximum absorbed current	6 A	
Cable station – control box	4 m - H07RN-F-4 G 1.5	
Control box cable – socket	2.5 m - H05VV-F-3 G 1,5	
Protection Station:	SANICUBIC® 1:	IP67
	SANICUBIC® 1 WP:	IP68
Control box:	IPX4	
Max. recommended height	11 m	
Max. flow	12 m ³ /hour	
Max. temperature of incoming wastewater	70°C (Max. 5 min.)	
Tank volume	32 L	
Usefull volume	10 L	
Height of low inlets (from the ground)	140 mm	
Gross Weight [KG]	SANICUBIC® 1:	19.8
(including packaging and accessories)	SANICUBIC® 1 WP:	26.7
Waste pipe	Ø ext. 50 mm	
Inlet	Ø ext. 40, 50, 100, 110 mm	
Ventilation	Ø ext. 50 mm	

SANICUBIC® 1 flow curve; SANICUBIC® 1 WP

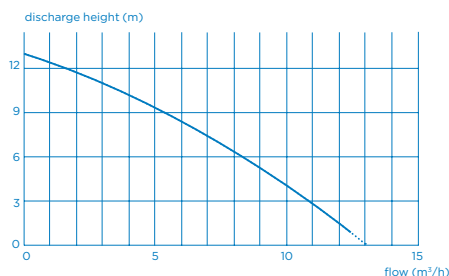

SANICUBIC® 2 Classic / SANICUBIC® 2 Pro

Type of current	Single-phase	
Voltage	220-240V	
Frequency	50/60 Hz	
Motor - Pump	Oil bath cooled Thermal overload protection Class F insulation	
Type of pump	Shredding by blade-plate	
Motor power consumption (for one motor)	1,500 W	
Maximum absorbed current	13 A	
Cable station – control box	4 m - H07RN-F-4 G 1.5	
Control box cable – socket	2.5 m - H05VV-F-3 G 1,5	
Protection Station:	IP68	
Control box:	IPX4	
Max. recommended height	11 m	
Max. flow	12 m ³ /hour	
Max. temperature of incoming wastewater	70°C (Max. 5 min.)	
Tank volume	45 L	
Usefull volume	17.5 L	
Height of low inlets (from the ground)	140 mm	
Gross Weight [KG]	SANICUBIC® 2 Classic:	35.5
(including packaging and accessories)	SANICUBIC® 2 Pro:	33.0

Waste pipe	Ø ext. 50 mm
Inlet	Ø ext. 40, 50, 100, 110 mm
Ventilation	Ø ext. 50 mm

SANICUBIC® 2 Classic flow curve; SANICUBIC® 2 Pro

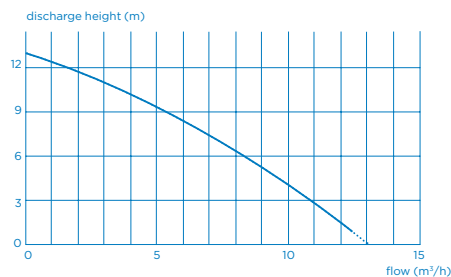

SANICUBIC® 2 XL

Type of current	Single-phase	
Voltage	220-240V	
Frequency	50/60 Hz	
Motor - Pump	Oil bath cooled Thermal overload protection Class F insulation	
Type of pump	Vortex Impeller (clearance: 50 mm)	
Motor power consumption (for one motor)	2,000 W	
Maximum absorbed current	16 A	
Cable station – control box	4 m - H07RN-F-4 G 1.5	
Control box cable – socket	2.5 m - H05VV-F-3 G 1,5	
Protection Station :	IP68	
Control box:	IPX4	
Max. recommended height	10 m (DN80) 7 m (DN100)	
Max. flow	40 m ³ /hour	
Max. temperature of incoming wastewater	70°C (Max. 5 min.)	
Tank volume	120 L	
Usefull volume	26 L	
Gross Weight [KG] (including packaging and accessories)	101.0	
Waste pipe	ND 100 (Ø ext. 110 mm) or ND80 (Ø ext. 90 mm)	
Inlet	Ø ext. 40, 50, 100, 110 mm	
Ventilation	Ø ext. 50 mm	

SANICUBIC® 2 XL Single-phase discharge bend

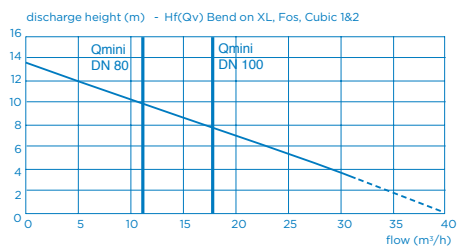

Self-cleaning speed limit: 0.7 m/s

SANICUBIC® 2 XL Three-phase

Type of current	Three-phase	
Voltage	230-400V	
Frequency	50/60 Hz	
Motor - Pump	Oil bath cooled Thermal overload protection Class F insulation	
Type of pump	Vortex Impeller (clearance: 50 mm)	
Motor power consumption (for one motor)	3,500 W	
Maximum absorbed current	12 A	
Cable station – control box	4 m - H07RN-F-4 G 1.5	
Control box cable – socket	2.5 m - H05VV-F-5 G 2.5	

Protection	Station: Control box:	IP68 IPX4
Max. recommended height		14.5 m (DN80) 13 m (DN100)
Max. flow		55 m ³ /h
Max. temperature of incoming wastewater		70°C (Max. 5 min.)
Tank volume		120 L
Usefull volume		26 L
Height of low inlets (from the ground)		102.0
Waste pipe		DN 100 (Ø ext. 110 mm) or DN80 (Ø ext. 90 mm)
Inlet		Ø ext. 40, 50, 100, 110 mm
Ventilation		Ø ext. 75 mm

SANICUBIC® 2 XL Single-phase discharge bend

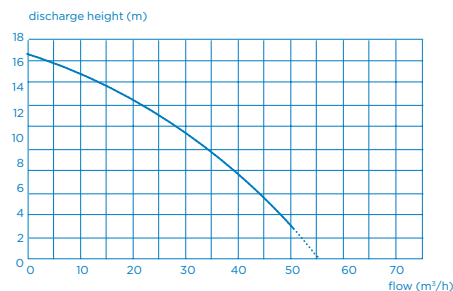

3.6 Control box

⚠ DANGER



Submersion of the control device
Risk of death by electric shock
▷ Only use the control device in rooms safe from floods

SANICUBIC® remote control box

- Pump control and monitoring cabinet integrated into a compact plastic housing
- For 1 or 2 pumps
- Option of forced mode

3.6.1 Electrical characteristics

Table 3: Electrical characteristics of the control box

Parameter	Value	
Nominal power supply	1 ~ 220-240 V AC	
Network frequency	50/60 Hz	
Protection index	IPX4	
Nominal current per engine		
	SANICUBIC® 1; SANICUBIC® 1 WP; SANICUBIC® 2 Classic; SANICUBIC® 2 Pro	6 A
	SANICUBIC® 2 XL Single-phase	8 A
	SANICUBIC® 2 XL Three-phase	6 A

3.6.2 Technical characteristics of the detection device

Analog level sensor:
• Input voltage 0 - 5 V

Process outputs:

- One potential-free signalling output (250 V, 16 A) NO Contact
- One signalling output for the wired alarm unit that comes with the device (except SANICUBIC® 2 Pro): 5V, 50mA

3.6.3 Dimensions of the remote control box

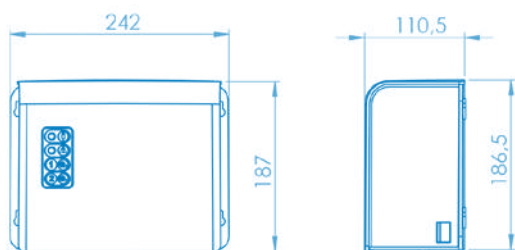

3.7 Alarm unit

3.7.1 Technical characteristics of the alarm device

SANICUBIC® alarm unit:

SANICUBIC® 1; SANICUBIC® 1 WP; SANICUBIC® 2 Classic; SANICUBIC® 2 XL:
Wired alarm unit
5m cable
Audio and visual information
Protection index: IP20

SANICUBIC® 2 Pro:

HF alarm unit 868 MHz (radio)
Unobstructed range: 100 m
Audio and visual information
Protection index: IP20

3.7.2 Dimensions of the remote alarm unit

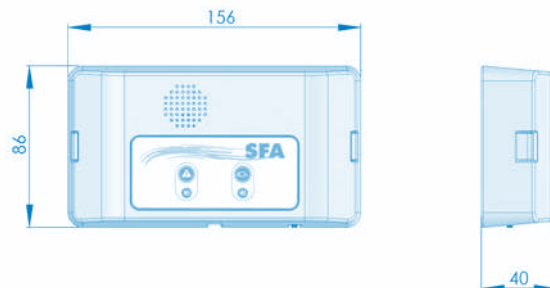

3.7.3 Option of connection to an external alarm

Option of externalising the alarm signal (depending on the model). Dry contact (no voltage) NO (normally open) operated by a max. 250V/16A relay.

The terminals can be connected to a powered system. This contact closes as soon as the station is in alarm mode (except in the case of area alarm) and remains closed as long as the alarm sounds.

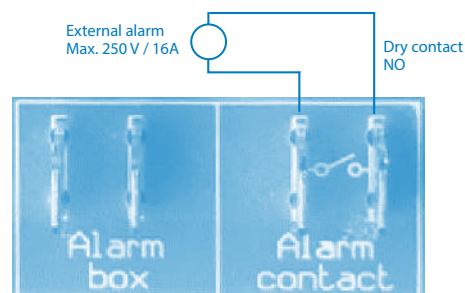

3.8 Sump tank

The sump tank is designed for pressure-free operation. Wastewater is collected there at atmospheric pressure before being discharged to the sewer. The ventilation duct allows the tank to always remain at atmospheric pressure

3.9 Pumped fluids

⚠ DANGER



Pumping unauthorised fluids
Dangerous for people and the environment!
▷ Only discharge authorised pumped fluids in the public sewerage network

Authorised pumped fluids:

The following liquids are allowed in discharge systems:

Water contaminated by domestic use, human excrement.

Unauthorised pumped fluids:

The following liquids and substances are banned:

- Solid materials, fibres, tar, sand, cement, ash, coarse paper, hand towels, wipes, cardboard, rubble, rubbish, slaughterhouse waste, oils, greases, etc.
- Wastewater containing harmful substances (for example, untreated greasy waste from restaurants). Pumping these liquids and substances requires the fitting of a compliant grease trap.
- Rain water.

3.10 Noise level

The noise level depends on the fitting conditions and operating point. This sound pressure level L_p is less than 70 dB (A).

4 INSTALLATION / FITTING

4.1 Installing the pumping station

- The characteristics shown on the rating plate have been compared with those on the order and installation (supply voltage, frequency).
- The installation room must be protected against frost.
- The installation room is adequately lit.
- The work has been prepared in accordance with the dimensions shown in the example installation and standard EN 12056-4.
- The plant room where the SANICUBIC® will be installed must be large enough to allow a 600 mm clearance around and above the device to facilitate maintenance.
- The alarm signal is always visible to the user (if necessary, use an external alarm contact switch).
- Stop valves (not provided) must be fitted on the effluent inlet as well as on the discharge line, as close as possible to the pumping station.
- The discharge line must be designed to prevent any back-flow of sewage. By fitting a non-return loop, located above the back-flow level, back-flow is avoided.

Comment: In the absence of local information to the contrary, the maximum back flow level corresponds to street level - roadway, pavements etc. Extend this line after the non-return loop through a larger diameter pipe.

- Provide a sump to drain the room.
- The installation of an auxiliary pump for possible drainage of the plant room (for floods) is recommended.
- The pumping station must be ventilated above the roof.
- The pumped fluid is appropriate and authorised by this documentation. (section 3.9, page 5)
- In case of discharge of greasy effluents, the use of a degreasing tank is essential.

Wastewater other than those mentioned above, for example, of artisanal or industrial origin, must not be discharged into the pipes without prior treatment.

4.2 Electrical connection

DANGER

Electrical connection work performed by an unqualified individual. Risk of death by electric shock!



- ▷ The electrical connection must be performed by a qualified and licensed electrician.
- ▷ The electrical installation must meet the current standards in the country

WARNING



Wrong supply voltage. Damage to the pumping station!

- ▷ The supply voltage must not differ by more than 6% of the rated voltage specified on the rating plate.

The power supply must be class 1. The device must be connected to an earthed junction box. The electrical power supply must be protected with a high sensitivity circuit breaker set to 10 Mini Amps for SANICUBIC 1/ SANICUBIC 1 WP and 20 Mini Amps for SANICUBIC 2 Classic/SANICUBIC 2 Pro/SANICUBIC 2XL single-phase and 25 Amps for SANICUBIC 2XL three-phase. This connection must be used exclusively for the SANICUBIC® power supply. If the cord of this device is damaged, it must be replaced by the manufacturer or its after-sales service in order to avoid any danger to users.

4.3 Fitting the pumping station

Fit the pumping station on the bare ground and level it with a bubble level.

To avoid any risk of the pumping station floating, attach it to the ground using the mounting kit provided.

NOTE

Pumping stations should not be installed near bedrooms and living rooms (noise from the pumping station). (⇒ section 3.10, page 5)



Fitting the pumping station on anti-vibration mounts ensures sufficient insulation against structure-borne sound with respect to the pumping station.

Do not fit the pumping station in direct contact with the walls to avoid transmission of the pumping station's vibrations.

4.4 Pipe connections

4.4.1 Inlet pipes

DANGER



- ▷ The pumping station must not be used as a control point for piping.
- ▷ Prop up the pipes upstream from the pumping station. Make connections without constraints.
- ▷ Use suitable means to compensate for thermal expansion of the piping.

NOTE



It is recommended that you mount check valves and stop valves on the inlet pipes. These must be mounted so that they do not hinder disassembly of the pumping station.

✓ The piping is supported.

1. Choose the connection openings to use.
2. Cut the tip of the corresponding boss with a saw

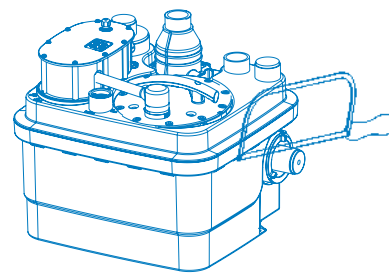

NOTE

All piping connections must prevent the propagation of noise and be flexible.

4.4.2 Discharge piping

WARNING



Improper fitting of the discharge pipe. Leaks and flooding of the installation room!

- ▷ Run the discharge line above the back-flow level before connecting to the sewer.
- ▷ The pumping station must not be used as a control point for piping.
- ▷ Do not connect other drain pipes to the discharge pipe.
- ▷ Fit isolation valves to inlets and discharge pipework.

NOTE



To prevent the risk of back-flow of water from the sewer, install the discharge pipe in a «loop» so that its base, at the highest point, is located above the back-flow level.

Fit a shutoff valve behind the check valve.

The check valves are equipped with a lever for emptying the discharge pipe into the tank.

4.4.3 Ventilation pipe

WARNING

Insufficient ventilation. Risk that the pumping station will not work!



- ▷ Ventilation must remain free
- ▷ Do not block the vent outlet
- ▷ Do not install an air intake valve (diaphragm valve).

According to the recommendations of EN 12050-1, it must be equipped with a vent above the roof. The pumping station must always be ventilated so that the tank is always at atmospheric pressure. The ventilation must be completely free and air must flow in both directions (no diaphragm valve fitted).

The vent pipe must not be connected to the vent pipe on the inlet side of a grease trap.

Connect the ND 50 or ND 70 vent pipe (depending on the model) vertically to the vent opening with the flexible couplings. The connection must be smell-proof.

4.5 Cellar drying

Automatic drying:

For automatic drainage of the installation room (in case a sump is installed, for example), especially in case of risk of water infiltration or flooding, a submersible pump for contaminated water must be fitted.

Figure 1: Example of installation with submersible pump:

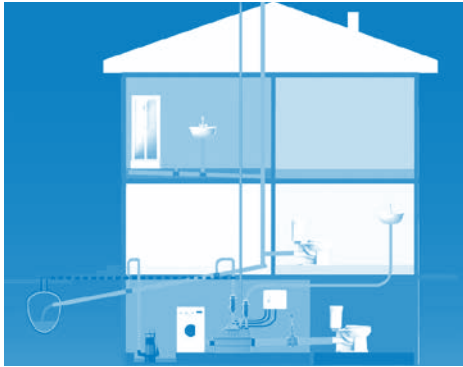

WARNING

Discharge line for drying the cellar connected to the discharge line of the pumping station.

Flooding of installation room!



- ▷ Run the discharge line of the cellar drainer above the back-flow level before connecting it to the sewer.
- ▷ Never connect the discharge line of the cellar drainer to the discharge line of the pumping station.
- ▷ Fit a check valve at the base of the discharge line
- ▷ Select the pump depending on installation conditions: (manometric delivery head $H [m] = \text{Static head} + \text{head loss}$).

5 COMMISSIONING / DECOMMISSIONING

5.1 Commissioning

5.1.1 Prerequisites for commissioning

Before commissioning the pumping station, make sure that the electrical connection for the pumping station and all protective devices has been correctly performed.

5.2 Application limit

DANGER



- ▷ Pressure and temperature limits exceeded. Leakage of hot or toxic fluid!
- ▷ Observe the operating specifications in the documentation.
- ▷ Avoid running the pump with the valve closed.
- ▷ Dry running, without pumped fluid, must be avoided.

When in use, observe the following parameters and values:

Parameter	Value
Max. allowed temperature of the fluid	40 °C up to 70 °C when pumped 5 minutes max.
Max. room temperature	50 °C
Operating mode	Intermittent service SANICUBIC® 1 / 1 WP: S3 30 % Intermittent service SANICUBIC® 2 Classic / Pro / SANICUBIC® 2 XL Single-phase: S3 50% SANICUBIC® 2 XL Three-phase: S3 30 %

5.3 Starting frequency

To prevent engine overheating and excessive stress on the engine, seals and bearings, limit the number of starts to 60 per hour.

5.4 Commissioning with the control box

DANGER



- ▷ The control box cover is not properly closed. Risk of death!
- ▷ Properly close the control box cover.
- ▷ Then reconnect the power plug.

Operations required for commissioning

1. Perform a functional and sealing test of the pumping station: Once the hydraulic and electrical connections are made, check the connections for leaks by running water successively through each inlet used. Ensure the device is operating properly and there are no leaks by performing a water test and observing several start cycles.
2. Check the various points on the checklist (⇒ section 7.6, page 10)
3. Warning: Do not run the motor in forced mode (by pressing the key on the keypad) before putting the pump in water. Dry running damages the grinding system.

5.5 Decommissioning

1. Close the valves on the inlet and discharge pipes.
2. Drain the tank by pressing the forced mode button on the pump.
3. Switch off the electrical power supply and record the installation.

DANGER



- ▷ The current is not cut. Risk of death!
- ▷ Unplug the plug or disconnect the electrical conductors and take the steps required to avoid inadvertent operation.

4. Inspect the hydraulic parts and shredding blades (depending on the model). Clean them if necessary.
5. Clean the tank.

DANGER



- ▷ Pumped fluids and secondary consumable materials that are harmful to health. Dangerous for people and the environment!
 - ▷ Pumping stations used to discharge fluids that may be harmful to health must be decontaminated.
- If necessary, wear a mask and protective clothing.
- ▷ Observe current legal provisions for the discharge of fluids harmful to health.

6 OPERATION

6.1 SANICUBIC® Control box

NOTE



This paragraph describes the operation of a control box for two pumps. The control box is operated in a similar manner for one pump.

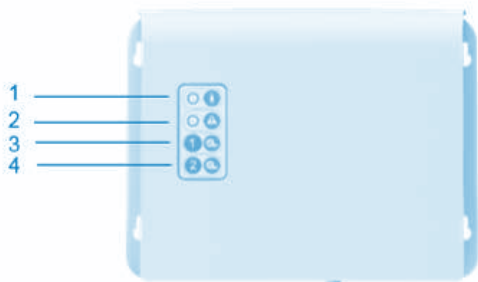

Table 4: SANICUBIC® remote control box

1	Yellow mains supply LED
2	Red alarm LED
3	Forced mode Engine 1
4	Forced mode Engine 2

LED lamps

The LED lamps provide information on the operating state of the control box: NOTE: On the SANICUBIC® 1, the control box is integrated on the top of the station's tank.

The detection system must be vented. Connect the vent turbine to the station's control box.

Figure 2: Ventilation of the SANICUBIC® control box

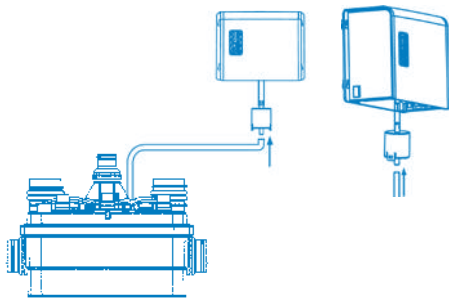

6.1.1. Operation of the SANICUBIC® 1 control keypad (IP67)

1/ General alarms:

Level alarm:

If the water level inside the device is abnormally high, the alarm LED lights up red + engine starts up. Furthermore, if this LED **flashes** red, it indicates a detection problem for the normal water level (Long dip tube).

Time alarm:

If the motor runs continuously for more than 1 minute, the red alarm LED lights up.

2/ Alarm reset: The button on the keypad will only allow you to turn off the red LED (it will turn green) if the problem that triggered the alarm has been resolved. It also allows you to stop the ringing of the remote alarm control.

Mains alarm:

- If the LED is off, there is no power supply.
- When the device is powered on again, the LED flashes green, indicating that the mains voltage has temporarily disappeared.

6.1.2 Operation of the SANICUBIC® 2 Classic /SANICUBIC® 2 Pro / SANICUBIC® 2 XL remote control box

OPERATION OF THE ALARM

1/ General alarms:

Level alarm:

If the water level inside the device is abnormally high: the siren is triggered + the red alarm LED lights up + both motors start-up. If this LED flashes red, it indicates a detection problem for the normal water level (Long dip tube).

Time alarm:

If one of the two motors runs for more than 1 minute: the siren is triggered + the red alarm LED lights up + the other engine starts-up.

Mains alarm:

In case of power failure (or when unplugging the device): the siren is triggered + the red alarm LED lights up + the yellow mains LED blinks.

2/ General alarm reset:

If the problem that triggered one of the alarms above disappears, the siren stops, but the red alarm LED remains lit as a reminder of the fact that the system encountered a problem. Either of the two keypad keys will stop the siren in all cases, but it will only turn off the red LED if the problem that triggered the alarm has been resolved. Alarms from the remote box will also remain active until the problem has been solved. This prevents the system from being «abandoned» by default.

6.2 SANICUBIC® alarm unit

To wall mount the unit, use the following figure as a guide:

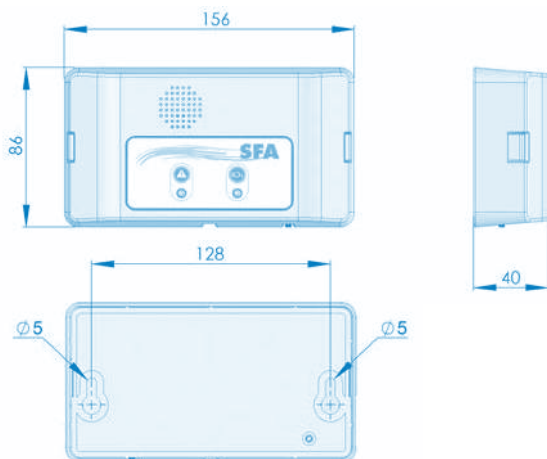

6.2.1 Operation of the SANICUBIC® 1 / SANICUBIC® 1 WP / SANICUBIC® 2 Classic /SANICUBIC® 2 XL wired alarm unit

The SANICUBIC® alarm unit does not require a separate power supply. The power is supplied through the SANICUBIC®. In case of power failure, the alarm unit's battery takes over.

Connection of the alarm unit to the device:

Connect the alarm cable directly to the unit.

1/ The red general alarm LED reproduces the operation of the red LED on the base card. The alarm unit sounds in the event of an alarm as long as the fault is present. To stop the alarm, press the reset (*) button on the device's keypad or the button under the alarm unit.

2/ The yellow «mains» LED indicates the power status of the alarm unit

-Steady light = live SANICUBIC® connected to the mains supply

-Flashing = power failure on the SANICUBIC®

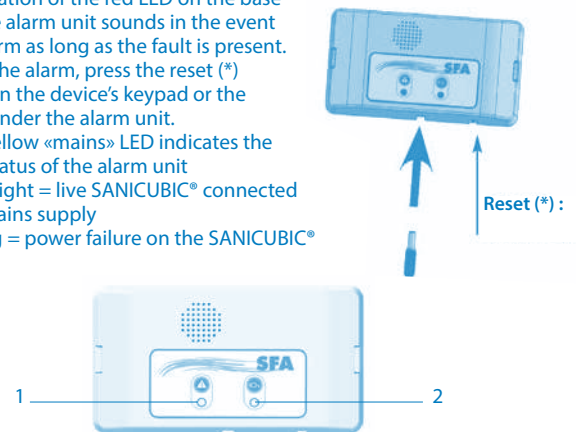

Table 5: SANICUBIC® 1 / SANICUBIC® 1 WP / SANICUBIC® 2 Classic / SANICUBIC® 2 XL alarm unit

1	Red general alarm LED
2	Yellow mains alarm LED (power supply indicator)

6.2.2 Operation of the SANICUBIC® 2 PRO HF alarm unit



DANGER

▷ Unit powered by an electrical socket. Risk of death!

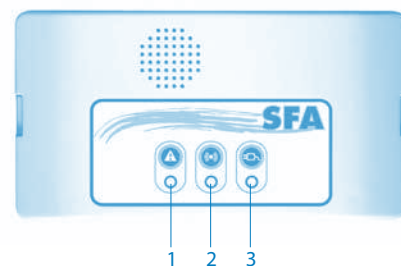
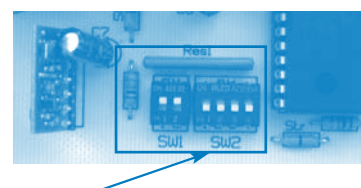

Table 6: SANICUBIC® 2 Pro alarm unit

1	Red general alarm LED
2	Yellow alarm transmission LED
3	Green mains alarm LED

The alarm unit is in HF -868 MHz connection with the SANICUBIC® 2 Pro. It receives various alarm information from it. If other devices operating in HF are disrupted by the system (or vice versa), a commutation of the HF -868 MHz coding, which connects the base card and the remote alarm unit, has been anticipated. In case of interference with other nearby HF devices or other SANICUBIC® 2 Pro devices, unplug the device and the remote module, switch one or more of the four switches on the device's card (SW2) and do likewise on the remote control unit.

Control box card

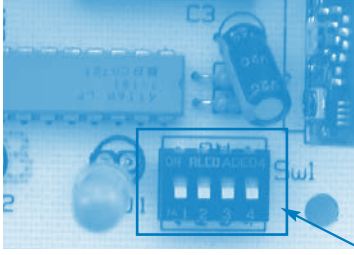

Alarm unit card

**Warning: the code must be the same for both cards.**

The alarm unit has 3 LEDs and 1 buzzer.

- 1/ The red «general alarm» LED reproduces the operation of the red LED on the base card.
- 2/ The yellow «HF reception» LED reproduces the operation of the base card's yellow mains LED:
 - steady = transmission OK, live base card
 - flashing = transmission OK, but mains fault on the base card (which then operates on battery)
 - off = no HF reception (make sure the code is the same as the one on the base card) or loss of HF signal (too far away) discharge, discharged battery or failure of the base card.
- 3/ The green «mains» LED indicates the power status of the remote alarm unit:
 - steady = live unit
 - flashing = mains fault on the unit (which then operates on battery)
 - off = failure of the unit or the unit's battery is discharged
- 4/ The buzzer sounds continuously during an alarm. It stops buzzing if the alarms disappear or if you press the general alarm reset button.

6.3 Messages and faults**Table 7: Messages and faults:**

Alarm on the device SANICUBIC® 1 and SANICUBIC® 1 WP:
Green LED: station live

Alarm on the device SANICUBIC® 2 Classic and SANICUBIC® 2 Pro and SANICUBIC® 2 XL: Yellow LED: station live

ANOMALY DETECTED	CAUSES PROBLEMS	SOLUTIONS
Flashing red alarm LED	<ul style="list-style-type: none"> • Water level detection system faulty 	<ul style="list-style-type: none"> • Consult SFA after-sales service
Steady red alarm LED	<ul style="list-style-type: none"> • Clogged vent pipe • Clogged drain line • Blocked or out of order pump • Discharge too high or excessive inflow 	<ul style="list-style-type: none"> • Check that air flows freely in both directions in the vent pipe • Go over the installation again • Consult SFA after-sales service
LED off	<ul style="list-style-type: none"> • Mains failure • Faulty electronic board 	<ul style="list-style-type: none"> • Check the electrical system • Consult SFA after-sales service

7 MAINTENANCE**7.1 General information / Safety instructions****⚠ DANGER**

Work performed on the pumping station by unqualified staff. Risk of injury!

- ▷ Repairs and maintenance must be performed by specially trained staff
- ▷ Observe the safety and basic instructions.

⚠ DANGER

Pumped fluids and secondary consumable materials that are harmful to health. Dangerous for people and the environment!

- ▷ Pumping stations used to discharge fluids that may be harmful to health must be decontaminated.
- ▷ If necessary, wear a mask and protective clothing.
- ▷ Observe current legal provisions for the discharge of fluids harmful to health.

7.2 Maintenance and inspection operations**⚠ DANGER**

Work on the pumping station without adequate preparation.

Risk of injury!

- ▷ Properly stop the pumping station and secure it against inadvertent operation.
- ▷ Close the inlet and discharge valves.
- ▷ Drain the pumping station.
- ▷ Close any auxiliary connections.
- ▷ Allow the pumping station to cool to room temperature.

In accordance with EN 12056-4, pumping stations must be maintained and repaired to ensure the proper disposal of wastewater and to detect and eliminate malfunctions at an early stage.

The proper functioning of pumping stations must be checked by the user once a month by observing at least two operating cycles.

The inside of the tank should be checked from time to time and deposits, especially around the level sensor, should be removed, if necessary

In accordance with EN 12056-4, maintenance of the pumping station must be performed by qualified staff. The following intervals should not be exceeded:

- 3 months for pumping stations for industrial use
- 6 months for pumping stations for small communities
- 1 year for domestic pumping stations

7.3 Maintenance contract

As with any technical, high-performance equipment, SANICUBIC® pumping stations must be maintained to ensure a sustainable level of performance. We recommend you take out a maintenance contract with a qualified company to carry out regular inspection and maintenance work. For more information, please contact us.

7.4 Emergency service with a single pump**NOTE**

If emergency service must be ensured during maintenance and inspection work, perform the following steps.

1. Close the valves on the inlet and discharge sides.

Warning: The incoming feed for inlets must be minimised while performing maintenance

2. Turn off the power supply.

7.5 Checking the hydraulics of each motor

- Make sure its blade and plate are not blocked or damaged (excluding SANICUBIC® 2 XL)
- Make sure the turbine rotates freely
- Make sure the hydraulic parts are clean. Clean them if necessary.

In case an motor is not working properly, it is possible to “disable” the use of this motor by switching the corresponding “switch” on the main card to indicate the absence of the corresponding motor. The card will only work with the valid motor - SW1: switch 1 and 2 for motor 1 (left) and 2 (right).



NOTE: If both switches are lowered (off position), abnormal situation, the card will be in alarm mode when power is restored

7.5.1 General information

Inspect the tank, check for possible deposits, the presence of grease and foreign bodies. Thoroughly clean the tank and remove foreign bodies.

7.5.2 Disassembling the motor

1. Unscrew the motor hatch from the tank cover (10 screws).
2. Use the handle to gently lift the motor. If the defective motor is to be returned to the manufacturer, the pumping station can provide a minimum service with one single motor.
3. Unscrew the screws of the faulty motor from the hatch.
4. Put the hatch back in position.

7.5.3 Disassembling and inspection of the compression chambers and level sensors:

1. Unscrew (1 screw), unlock and lift the pressure switch from the cover.
2. Check that the funnels are not obstructed (grease, faecal matter etc.). Clogged compression chambers indicate that the device has not been properly maintained. It is recommended to clean the device at least every 6 months.
3. If necessary unclog the compression chambers.

7.5.4 Reassembly of the level sensors

Warning: Do not grease the level sensors' O-rings before reassembly.

1. Fully insert the level sensor in the compression chamber.
2. Screw the level sensor onto the cover.

7.5.5 Reassembly

During reassembly, observe the following points:
 To reassemble the pump, observe the rules applicable to engineering goods. Do not over-tighten the screws on plastic parts (risk of breaking the plastic) and clamps.
 Clean all disassembled parts and check their wear.
 Replace damaged or worn parts with original spare parts.
 Ensure that the sealing surfaces are clean and the O-rings are properly installed.

7.5.6 Tightening torque

The tightening torque for screws and clamps is 2 ± 0.1 N.m

7.6 Checklist for commissioning / inspection ① and maintenance ②

Operations	Required for	
Read the operating manual.	①	②
Check the power supply. Compare the values with those of the rating plate.	①	②
Check the connection of the power supply to the earth.	①	②
Check the connection of the power supply to a 30 mA GFCI breaker.	①	②
Check the proper operation of the motors by pressing the forced mode buttons. If abnormal, make sure the pump is not clogged, check the resistance values of the engine coils. Where SANICUBIC 2 XL three-phase version is used, check the motor rotation direction by dismantling the motor.	①	② 2XL three-phase version
Check the sump tank. Clean the tank in case of deposits. In case of significant grease deposits in the tank from greasy wastewater from artisanal or industrial businesses, inform the customer that they must install a grease trap upstream from the pumping station.	①	②
Check the level sensors. Dismantle the pressure switches and make sure that the dip tubes are not clogged. Clean them if necessary.	①	②
Check the control mechanism. Dismantle the level sensor. Check if it is blocked or encrusted. Clean them, if necessary.	①	②
Perform a functional test over several cycles.	①	②
Check the correct installation and state of wear of the flexible couplings.	①	②
Check the proper operation and effectiveness of the alarm device.		②
Check the proper operation and seal of the stop valves and check valves.	①	②
If applicable, identify the necessary spare parts.	①	②
Advise and/or train operating staff.	①	②

NOTE



Before working inside the pump during the warranty period, you must consult the manufacturer. Our after-sales service is available to you. Failure to comply leads to the loss of rights to damages.

⚠ DANGER



Inappropriate work aiming to eliminate malfunctions. Risk of injury!
 ▷ For all work intended to eliminate malfunctions, follow this operating manual's instructions and / or the manufacturer's documentation for the relevant accessories.



NOTE

After every flood, the pumping station should be inspected.



NOTE

After an incident, subject the pumping station to functional test and visual inspection.

For any problem not described in the table below, contact SFA after-sales service.

Problems encountered:

- A The pump does not flow
- B Insufficient flow
- C Excessive current / power consumption
- D Insufficient manometric delivery head
- E Irregular and noisy operation of the pump
- F Frequent faults reported by the pumping station
- G Overflow of the pumping station
- H Untimely start

Before working on pressurised components, reduce the pressure inside the pump! Disconnect the pump from the electrical power supply.

8. Incidents: causes and solutions

A	B	C	D	E	F	G	H	Possible cause	Solutions
-	✗	-	-	-	✗	-	-	Pump flows against excessive pressure.	The size of the pumping station is insufficient for these operating conditions.
-	✗	-	-	-	✗	-	-	The discharge valve is not fully open.	Open the valve to the maximum.
✗	-	-	-	-	✗	-	-	The pumping station is not ventilated.	Check the pumping station's vent pipes
-	✗	-	✗	✗	✗	-	-	Inlet pipes or wheel clogged.	Remove deposits in the pump and/or piping.
-	-	✗	-	✗	✗	-	-	Presence of deposits / fibres in the wheel. The rotor does not turn freely.	Check if the wheel turns freely without blocking. If necessary, clean the pump.
✗	-	-	-	-	✗	✗	-	The engine is off.	Check the electrical installation (and fuses).
✗	-	-	-	-	-	-	-	Trigger of the thermal protection due to excessive temperature.	The engine automatically restarts after cooling.
-	✗	-	-	-	✗	-	-	Deposits in the sump tank.	Clean the sump tank. In case of grease deposits, make sure there is a grease trap.
-	-	-	-	-	✗	-	✗	The check valve is leaky.	Clean the check valve.
-	-	-	-	✗	-	-	-	Vibrations in the installation.	Check the flexible pipe connections.
✗	-	-	-	✗	✗	✗	-	Faulty, clogged, pulled out or improperly inserted level sensor.	Check the level sensor. Clean or replace it, if necessary.
-	-	-	-	✗	-	-	-	Faulty capacitor	Replace the capacitor
-	✗	-	✗	-	-	-	-	In the case of three-stage installation: 2 phases may be inverted. To check, visually look at the motor rotation direction by dismantling the motor.	With the connection, inverse 2 power cable phases (5 wires).

APPENDICES

SANICUBIC 1 - SANICUBIC 1 WP sizing diagram

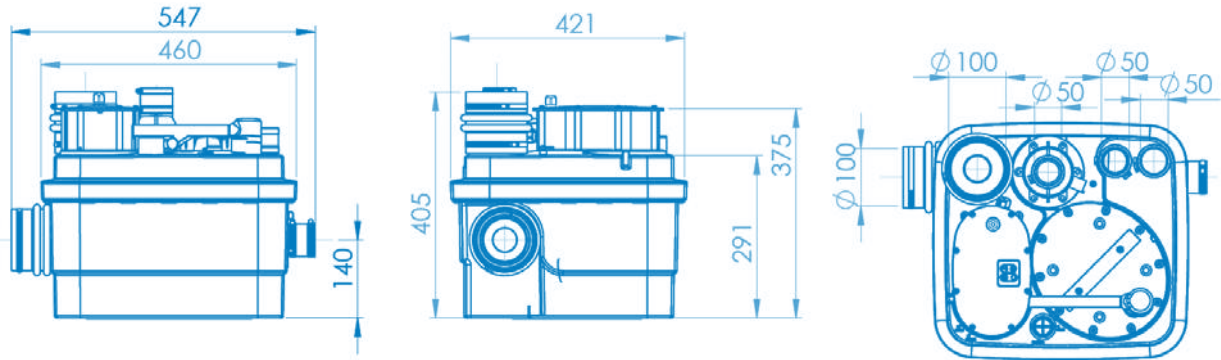

SANICUBIC® 2 Classic – SANICUBIC® 2 Pro sizing diagram

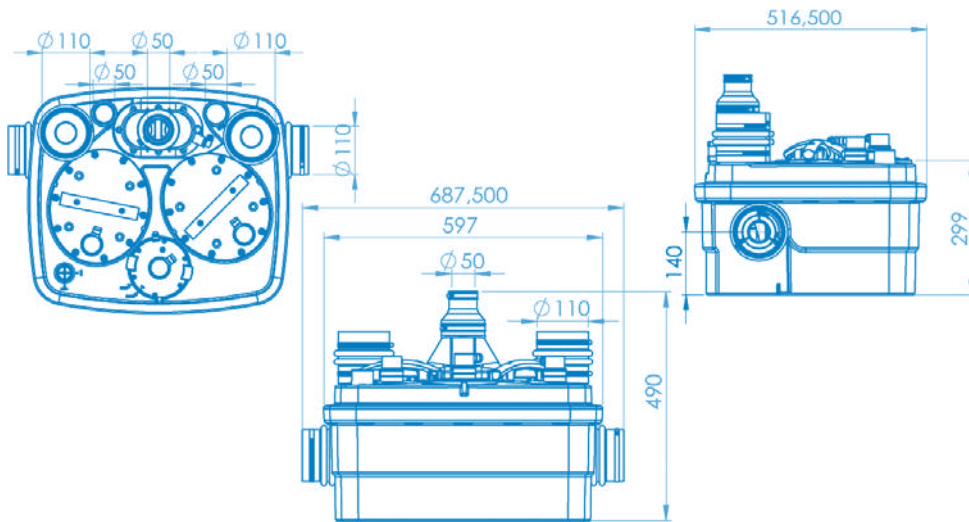

Dimensional drawing SANICUBIC® 2 XL

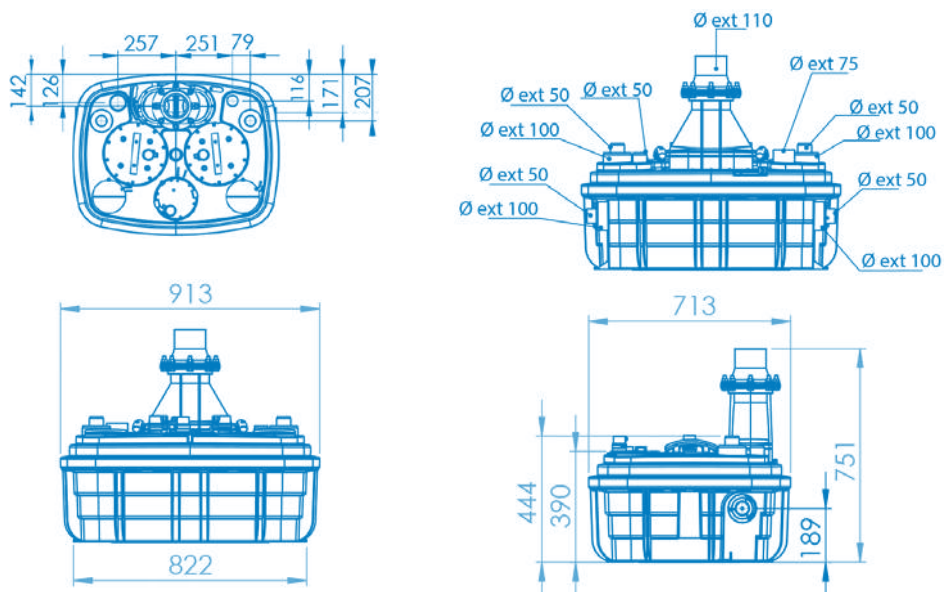

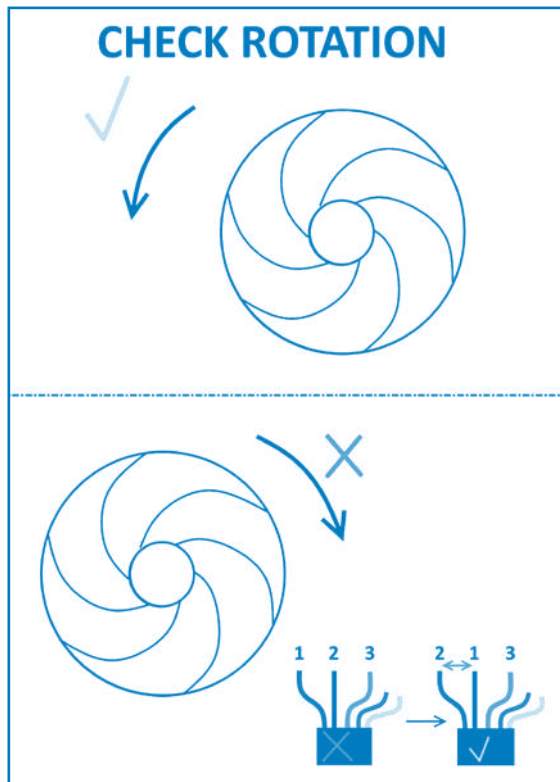
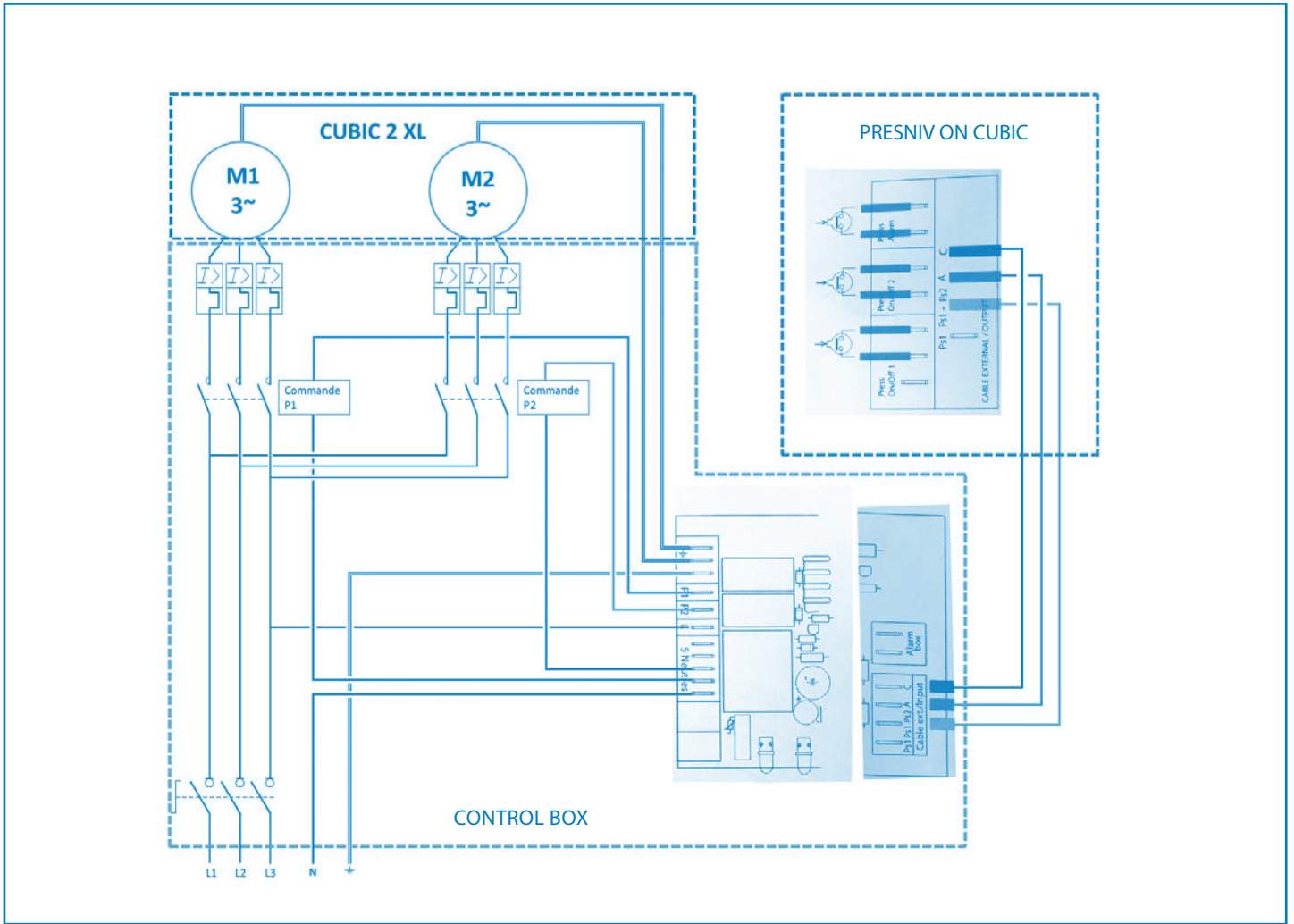

FRANCE
**SOCIÉTÉ FRANÇAISE
D'ASSAINISSEMENT**
41Bis, Avenue Bosquet - 75007 Paris
Tél. + 33 1 44 82 39 00
Fax + 33 1 44 82 39 01

UNITED KINGDOM
SANIFLO Ltd.,
Howard House, The Runway
South Ruislip Middx.,
HA4 6SE
Tel. +44 208 842 0033
Fax +44 208 842 1671

IRELAND
SANIRISH Ltd
IDA Industrial Estate
Edenderry - County Offaly
Tel. + 353 46 9733 102
Fax + 353 46 97 33 093

AUSTRALIA
Saniflo (Australasia) Pty Ltd
Unit 9-10, 25 Gibbes Street
Chatswood
NSW 2067
Tel. +61 298 826 200
Fax +61 298 826 950

DEUTSCHLAND
SFA SANIBROY GmbH
Waldstr. 23 Geb. B5 - 63128 Dietzenbach
Tel. (060 74) 30928-0
Fax (060 74) 30928-90

ITALIA
SFA ITALIA spa
Via del Benessere, 9
27010 Siziano (PV)
Tel. 03 82 61 81
Fax 03 82 61 8200

KOREA
www.sfa.biz
sales@saniflo-korea.kr

ESPAÑA
SFA SI
C/ Vinyalets, 1 - Pl. Can Vinyalets
08130 Santa Perpètua de Mogoda
Barcelona
Tel. +34 93 544 60 76
Fax +34 93 462 18 96

PORTUGAL
SFA, Lda.
Sintra Business Park, ed. 01-1°P2710-089
SINTRA
Tel. +35 21 911 27 85
Fax. +35 21 957 70 00

SUISSE SCHWEIZ SVIZZERA
SFA SANIBROY AG
Vorstadt 4
3380 Wangen a.A
Tel: +41 (0)32 631 04 74
Fax: +41 (0)32 631 04 75

BENELUX
SFA BENELUX B.V.
Völtaweg 4
6101 XK Echt (NL)
Tel. +31 475 487100
Fax +31 475 486515

SVERIGE
SANIFLO AB
BOX 797
S-191 27 Sollentuna
Tel. +08-404 15 30
info@saniflo.se

POLSKA
SFA POLAND Sp. z O.O.
ul. Białolecka 168
03-253 Warszawa
Tel. (+4822) 732 00 32
Fax (+4822) 751 35 16

РОССИЯ
SFA РОССИЯ
101000 Москва - Колпачный переулок 9а
Тел. (495) 258 29 51
факс (495) 258 29 51

ČESKÁ REPUBLIKA
SFA-SANIBROY, spol. s r.o.
Sokolovská 445/212, 180 00 Praha 8
Tel : +420 266 712 855
Fax : +420 266 712 856

ROMANIA
SFA SANIFLO S.R.L.
145B Foisorului Street District 3
31177 BUCURESTI
Tel. +40 256 245 092
Fax +40 256 245 029

TÜRKIYE
SFA SANIHYDRO LTD ŞTİ
Mecidiye Cad No:36-B Sevensan Apt.
34394 MECIDIYEKOY - ISTANBUL
Tel : +90 212 275 30 88
Fax : +90 212 275 90 58

CHINA
SFA 中国
上海市静安区石门二路333弄3号振安广
场恒安大厦27C室 (200041)
Tel. +86(0)21 6218 8969
Fax +86(0)21 6218 8970

BRAZIL
SFA Brasil Equipamentos Sanitários
Rua Maria Figueiredo 595,
CEP : 04002-003 São Paulo, SP
Tel : (11) 3052-2292
sanitrit@sanitrit.com.br
www.sanitrit.com.br

SOUTH AFRICA
Saniflo Africa (PTY) Ltd
Unit A6 , Spearhead Business Park
Cnr. Freedom Way & Montague Drive
Montague Gardens, 7441
Tél : +27 (0) 21 286 00 28
info@saniflo.co.za
www.saniflo.co.za

NEW ZEALAND
Saniflo New Zealand Ltd
PO Box 383 Royal Oak,
Auckland 1345
Tel : 09 390 4615
Fax : +61 2 9882 6950

SERVICE HELPLINES

France
United Kingdom
Ireland
Australia
Deutschland
Italia
España
Portugal
Suisse Schweiz Svizzera
Benelux
Sverige
Norge
Polska
Россия
Česká Republika
România
Türkiye
Brazil
中国
South Africa

TEL
01 44 82 25 55
08457 650011 (Call from a land line)
1850 23 24 25 (LOW CALL)
+1300 554 779
0800 82 27 82 0
0382 6181
+34 93 544 60 76
+35 21 911 27 85
+41 (0)32 631 04 74
+31 475 487100
+08-404 15 30
+08-404 15 30
(+4822) 732 00 33
(495) 258 29 51
+420 266 712 855
+40 256 245 092
+90 212 275 30 88
(11) 3052-2292
+86(0)21 6218 8969
+27 (0) 21 286 00 28

FAX
03 44 94 46 19
020 8842 1671
+ 353 46 97 33 093
+61.2.9882.6950
(060 74) 30928-90
+39 0382 618200
+34 93 462 18 96
+35 21 957 70 00
+41 (0)32 631 04 75
+31 475 486515

(+4822) 751 35 16
(495) 258 29 51
+420 266 712 856
+40 256 245 029
+90 212 275 90 58

+86(0)21 6218 8970