

Features:

- energy-efficient, explosion-proof sewage pump made of cast iron for portable and stationary (coupling system) purposes
- robust, adjustable cutting system made of corrosion-resistant special alloy
- motor housing, pump housing, seal carrier and impeller made of cast iron
- double bidirectional mechanical seals with intermediate oil chamber
- horizontal pressure outlet with flange DN 50
- lateral cable gland with strain relief and kink protection
- protection grade IP 68 – fully submersible

Application:

- pumping of sewage from collection sumps
- pressure drainage
- installation in polyethylene or concrete manholes
- as grinder pump on sewage lifting units

Scope of delivery:

- pump with 10 m power cable
- all pumps without stand feet and outlet bend
- optional coupling system (see accessories)



Product benefits:

- high performance cutting system (adjustable cutting gap; pre-adjusted to ≤ 0.05 mm)
- easily cuts textiles
- explosion-proof version
- double mechanical seal protects motor from incoming water
- available as complete system incl. FPS pumping station or as guide rail system with coupling for existing manholes

Technical data:

| Art.no. | U [V] | P ₁ [W] | P ₂ [W] | I _n [A] | n [min ⁻¹] | Q _{max} [m ³ /h] | H _{max} [m] | P0 | Weight [kg] |
|---------|-------|--------------------|--------------------|--------------------|------------------------|--------------------------------------|----------------------|-------|-------------|
| 17383 | 3~400 | 2.100 | 1.700 | 3,7 | 2800 | 17,0 | 25,0 | DN 50 | 46 |

Characteristics:

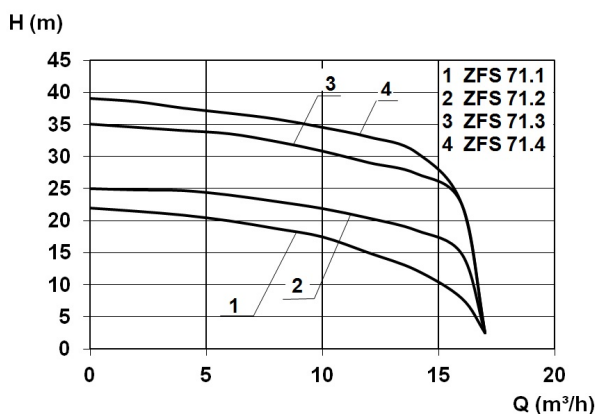

Materials:

| | |
|-------------------------|-----------------------------|
| Material impeller: | cast-iron GG25 |
| Seal motor: | mechanical seal SIC/SIC/NBR |
| Seal pump: | mechanical seal SIC/SIC/NBR |
| Material motor housing: | cast-iron GG25 |
| Material pump housing: | cast-iron GG25 |
| Material motor shaft: | stainless steel AISI 420 |

Dimensions:

portable application

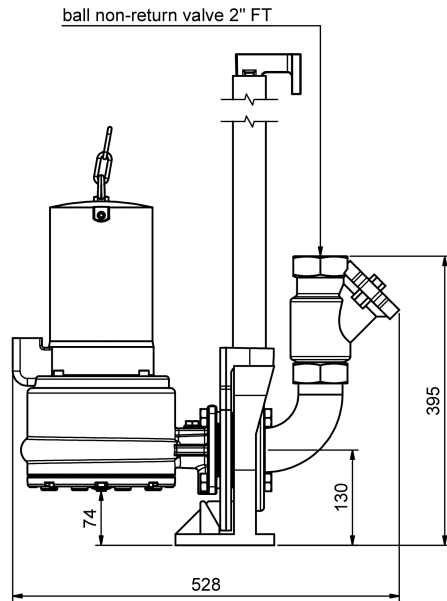

fixed application

