

Sanicom 2

Grey water

Sanicom 2 is an automatic grey water lifting station with two powerful motors that can be used in busy commercial applications such as restaurants, pubs, hair salons, cafes etc. as the second motor acts as a failsafe backup. Suitable for multiple connections this unit can handle temperatures up to 90°C for short periods of time (max 5 mins). The second pump assists the first in case of a sudden large intake of water. The tank is equipped with 2 immersion tubes controlling the motor and the alarm system.



PERFORMANCE

- Max. head : 12 m
- Max. flow rate : 18 m³/h

PRODUCT BENEFITS

- Grey water lifting station
- Floor standing for easy installation
- Easily accessible for maintenance
- 2 side inlets with outer diameter 40/50/80
- 2 pumps operate alternately for more even use
- Remote control box comes as standard
- Alarm can be fitted if required



See page 10



DELIVERED AS STANDARD



Classic control Box

PACK CONTAINS

Sanicom 2, 2 non-return valve, connectors, control unit (2 m cable)

OPTIONAL EXTRAS



Wired, audible and visual alarm box
Product code: 30521
Barcode: 3308815084107



Sanicubic carbon filter
Product code: 1108
Barcode: 3308815077529

DIMENSIONS

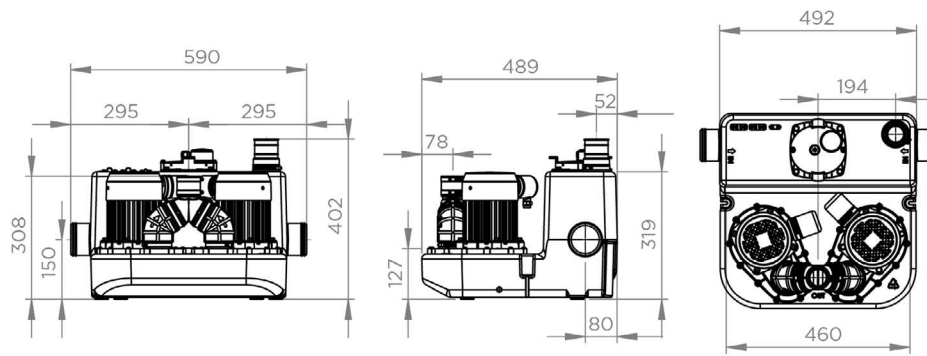

CURVE

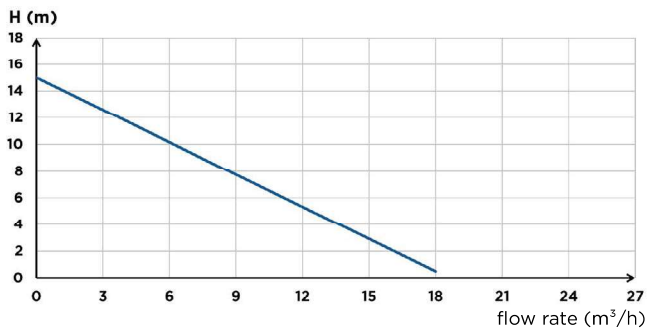

CONNECTIONS

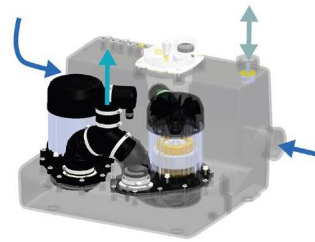

- External inlet diameter : 40/50/80 mm
- Discharge diameter ext. : 50 mm
- Ext. ventilation diameter : 50 mm

	Sanicom 2
Type of control box	Classic
Material	
Tank	PE
Pump housing	PA 12 GF
Motor housing	Aluminium
Impeller	PA 6 GF
Electrical features	
Voltage (V)	230
Frequency (Hz)	50-60
Power consumption P1 (W)	1500
Power output P2 (W)	1050
IP rating	IPX4
Hydraulics	
Max. head (m)	12
Max. flow rate (m ³ /h)	18
External inlet diameter (mm)	40/50/80
Discharge diameter ext. (mm)	50
Ext. ventilation diameter (mm)	50
Total volume (L)	34
Useable volume (L)	13
ON level /OFF level (mm)	145/60
Alarm level (mm)	215
Particle size (mm)	8
Max. temperature of the pumped liquid (5 min)	90°C
Type of impeller	multi-channel
Type of activation	pneumatic
Identification and logistics	
Gross weight (kg)	25
EAN code	3308815082868
Product code	30004