

The Sanicubic® 2 Classic contains two separate, load balanced pumps with high performance macerating systems and will operate alternately. In the event of inflow overload, both motors run at the same time, or in the unlikely event that one motor fails, the other one will take over.

Why choose this product?

- Ideal for busy business environments and larger domestic situations
- Tough, reliable macerator pump
- New design with easily removable motor for servicing and maintenance
- Water level indicator unit can be easily removed for maintenance
- Load balanced twin macerator pumps for a failsafe system
- Alternate activation ensures even wear of motors
- Two alarms for ultimate safety – both hard-wired
- Centre heights of inlets 140mm
- Working temperature of 35°C. Will handle up to 70°C for short periods. (See Sanicom 1 and 2 for higher temperatures and longer periods)
- IP68 rated
- Can be connected to a Building Management System



Note: Isolation valves must be fitted to the inlet pipework and discharge pipework to isolate the unit in case of the need for service – see page 23

Discharge Pipework 50mm	Working Waste Water Temp 35°C/Max 70°C (Intermittent)
Motor Power 1500 Watts x 2	Product Weight 36kg
Flow Rate 13m ³ /h	Inlet Pipework 40 / 50 / 100 / 110mm
Voltages 220-240 V/50 Hz	IP Rating IP68
Tank Volume 45L	

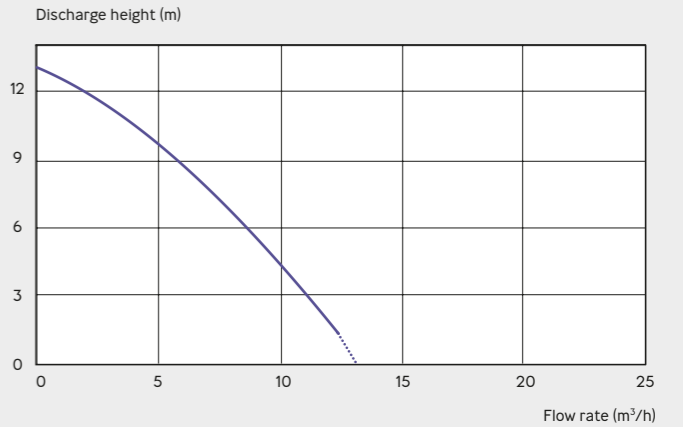

Vertical/horizontal performance

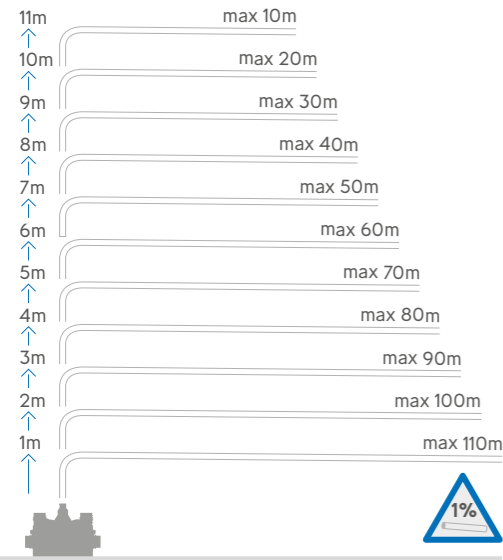

The Sanicubic tank is fitted with 2 dip tubes; one tube controls motor operation and the other controls the alarm system:

- Long pickup tube (normal operation): as soon as the waste water level in the tank reaches the triggering point in the long tube, the pumping system starts up.
- Short pickup tube (inflow overload operation): if the waste water level in the tank reaches the upper point, a contact is closed and the auxiliary pumping system is triggered. The contact also sets off an audible and visual alarm.

IP Ratings

IP or "Ingress Protection" ratings specify the environmental protection that the product casing provides and are defined by international standards. They are used to explain levels of sealing effectiveness of electrical enclosures against intrusion from foreign bodies e.g. dust, dirt and moisture.

Sanicubic 2 Classic has rating IP68 which gives protection against continuous submersion in water.



Includes hard-wired alarm on externally mounted control box plus secondary hard-wired audio visual alarm with 5m cable, so it can be placed remotely.

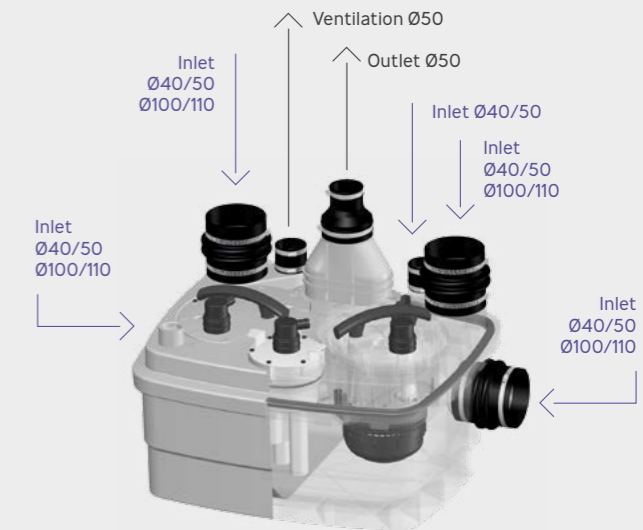
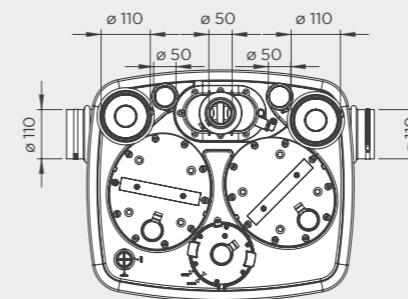
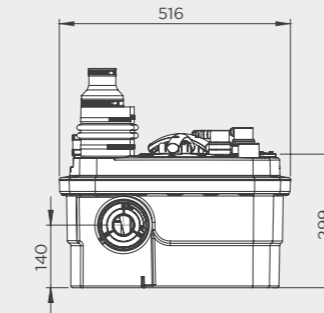
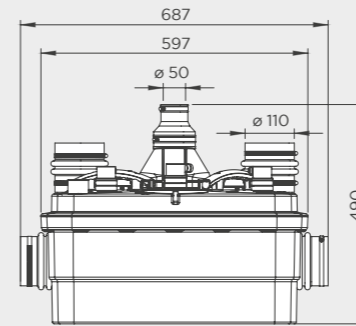

Externally mounted control box

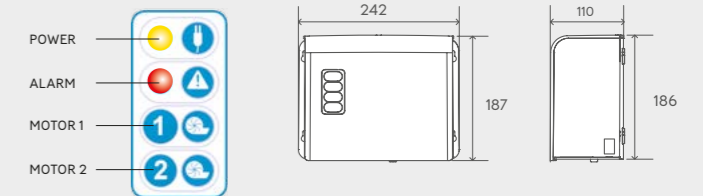

Remote wireless alarm

